



Physical Logic

MAXL-CL-3015 Datasheet

Part Number: 32010115-10/ 32010115-15/ 32010115-20 / 32010115-30

MAXL-CL-3015 is a high performance accelerometer based on a unique MEMS device and ASIC designed for tactical navigation applications, providing a digital acceleration output.

A highly advanced device, the MAXL-CL-3015 features an input range of ± 15 g and operates from a single power supply voltage of 5 V with < 75 mA current consumption. The sensor's system is composed of an LCC44 hermetically sealed package mounted on an interface board for customer evaluation and prototype testing. According to specified ICD, Physical Logic offers its customers assembly and testing of accelerometers on customer integration boards.

Features

- ❖ Sensing range ± 15 g
- ❖ Single-axis sensing
- ❖ Temperature output for thermal compensation
- ❖ High resolution
- ❖ High bias and scale factor stability
- ❖ Hermetic packaging
- ❖ Low profile, small form factor, LCC44 package
- ❖ Low weight





Physical Logic

Table of Contents

1	Accelerometer Functional Characteristics	3
2	Accelerometer Environmental Characteristics	5
3	Absolute Maximum Ratings	6
4	Physical specifications.....	6
5	Operational Principles.....	7
6	Electrical Interface	8
7	Pin configuration and function description	8
8	Temperature Sensor	9
9	Quality.....	9

List of figures

Figure 1	Simplified view of sensor interface	7
Figure 2	Connector pin-out (Top View)	8

List of tables

Table 1	Accelerometer Functional characteristics.....	3
Table 2	Accelerometer Environmental characteristics	5
Table 3	Absolute maximum ratings	6
Table 4	Physical specifications	6
Table 5	Pin description.....	8
Table 6	Temperature Sensor Specifications	9

1 Accelerometer Functional Characteristics

Table 1 Accelerometer Functional Characteristics

Parameter	Units	MAXL-CL-3015-10	MAXL-CL-3015-15	MAXL-CL-3015-20	MAXL-CL-3015-30
Input Range	g	±15	±15	±15	±15
Bias					
Null Bias @25°C	mg (max)	10	10	10	5
Short Term Stability 5h	µg (max)	180	150	150	100
One-year Repeatability	µg (max)	4000	2000	1200	500
Temperature Sensitivity	µg/°C (max)	600	300	300	150
Temperature Residual Error	µg (max)	600	450	300	150
Scale Factor					
Scale Factor @25°C	mbit/g	20±0.01	20±0.01	20±0.01	20±0.01
Short Term Stability 5h	ppm (max)	150	100	100	80
One-year Repeatability	ppm (max)	800	600	400	400
Temperature Sensitivity	ppm/°C (max)	200	150	150	150
Temperature Residual Error	ppm (max)	300	200	200	200
Misalignment					

Parameter	Units	MAXL-CL-3015-10	MAXL-CL-3015-15	MAXL-CL-3015-20	MAXL-CL-3015-30
Misalignment @25°C	mrad (max)	10	10	10	10
Temperature Residual Error	μrad (max)	100	50	50	50
Other					
Turn On to Turn On Repeatability @25°C	μg (max)	250	200	200	100
SF Linearity Error	ppm of input acceleration over full range (max)	300	300	300	300
Resolution/Threshold	μg (max)	50	50	50	50
Bandwidth	Hz	>300	>300	>300	>300
Equivalent Noise Density over Bandwidth	μg/√Hz (max)	50	50	50	50
Vibration Rectification Error (20-2000 Hz)	μg/g ² _{RMS} (max)	30	25	25	20

2 Accelerometer Environmental Characteristics

The accelerometer is qualified according to the Table 2

Table 2 Accelerometer Environmental Characteristics

Operating temperature range	-40°C to +85°C
Storage temperature range	-54°C to +90°C
Operational vibration	5 g RMS, 20-2000 Hz, 2 h each axis
Non-operational vibration (Transportation by track)	MIL-STD-810G METHOD 514.6, 1 h each axis
Operational shock	40 g 11 msec., saw tooth, 2 shocks each axis
Non-operational shock	75 g 6 msec., saw tooth, 2 shocks each axis
Non-operational high shock	500 g 1 msec., half sine, 2 shocks each axis
ESD sensitivity	Class 2 (MIL-STD-883-G), HBM 2 kV

3 Absolute Maximum Ratings

Stresses above those listed as “absolute maximum ratings” may cause permanent damage to the device. This is a stress rating only and functional operation of the device under these conditions is not implied. Exposure to maximum rating conditions for extended periods may affect device reliability.

Table 3 Absolute maximum ratings

Ratings	Unit	Maximum value
Supply Voltage (VIN)	V	4 - 6
Operating Temperature Range	°C	-54 to 90

4 Physical specifications

Table 4 Physical specifications

Packaging	LCC, 44 pin
Sealing	Hermetically sealed. Sealing process is qualified at $5 \cdot 10^{-8}$ atm·cm ³ /s (requirements MIL-STD-883-E)
Weight	< 3 gram (Package Only)
Package size	16.5X16.5X3.4 mm

5 Operational Principles

The MAXL-CL-3015 is a complete one axis acceleration measurement system with a measurement range of ± 15 g.

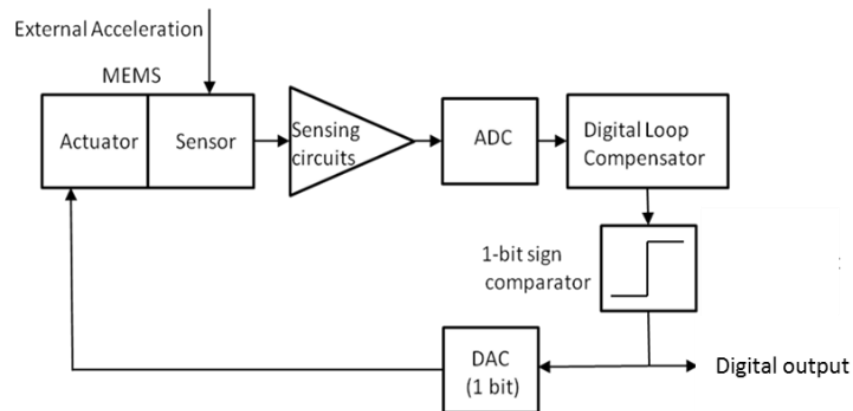

Figure 1 Simplified view of sensor interface

Figure 1 illustrates a block diagram of a Sigma-Delta servo accelerometer, MAXL-CL-3015 represents. The proof mass position of the sensor is captured through sensing circuits. The signal is then digitalized in a low resolution A/D converter before being processed in a digital loop compensator. The output of the compensator is put through a 1-bit sign comparator to get a single bit stream. This bit stream carries the acceleration signal information in a 1-bit format at highly oversampled ratio. The signed 1-bit data coming out of the comparator is then fed back in a 1-bit D/A converter to generate an actuation force pulse on the MEMS sensor.

6 Electrical Interface

Connector type: Samtec TFM-105-02-L-D-WT

N.C.	9	10	GND
CLK_OUT	7	8	N.C.
DATA_OUT	5	6	N.C.
N.C.	3	4	N.C.
Vin	1	2	TEMP

Figure 2 Connector pin-out (Top View)

7 Pin configuration and function description

Table 5 Pin description

Pin #	Name	Description
1	Vin	Supply Voltage. 5 V (< 75 mA)
2	TEMP	Temperature sensor reading. Analog output.
3	N.C.	Not connected
4	N.C.	Not connected
5	DATA_OUT	Single bit Output data. Digital out, ~780 kHz, 3.3 V.
6	N.C.	Not connected
7	CLK_OUT	Single Bit Output clock (rising edge). Digital out, ~780 kHz, 3.3 V.
8	N.C.	Not connected
9	N.C.	Not connected
10	GND	Ground

8 Temperature Sensor

The temperature sensor in the MAXL-CL-3015 accelerometer reflects the sensor's junction temperature and provides a convenient temperature measurement for system-level characterization and calibration feedback.

Table 6 Temperature Sensor Specifications

Parameter	Units	Value
Range	°C	- 45 to + 85
Output at 20 °C	V	1.0 ± 0.1
Typical sensitivity	mV/ °C	8.2 ± 0.5
Short term stability	°C	0.01
Accuracy	°C	± 2

9 Quality

- Physical Logic is ISO 9001 and AS9100D certified
- MAXL-CL-3015 is qualified according to Mil-STD-810G

Physical Logic reserves the right to update the content of this datasheet without notice.